

NO-COVER MANUAL WALLMOUNT DISPENSER

FOAMING HAND DISPENSER

Prevent the spread of harmful germs & bacteria at the source by using our Foaming dispensers in your facilities. **With 3,000 applications between refills, our dispenser provides a controlled amount of foam formula** where hand hygiene is required.

HIGHLIGHTS & FEATURES

- Provides 3,000 applications inbetween refills reducing maintenance trips required.
- Foam pump dispenses consistent & controlled amounts of formula to reduce mess.
- Place Foam dispenser in high-traffic area's to reduce the spread & transmission of illness causing germs & bacteria at the source.
- Light-weight and sleek design allows easy installation using screws or adhesive tape.
- Fully ADA Compliant dispenser meeting one-handed operation standards.

CLEAN-TIP TECHNOLOGY

Soapopular 10111 and 10111-NC cartridges are equipped with 7th generation foam tips that pull foam liquid back in the pump after application to completely erase wasteful leaks & spills. A more hygienic dispensing product.



CONSISTENT & RELIABLE



RICH FOAM FORMULA

Foam formula offers 2.5x more applications than gel and liquid.



3,000 APPLICATION

From start to finish, our dispenser applies a controlled amount of foam product.

Website: www.soapopular.com
E-mail: info@soapopular.com

DISPENSER MOUNTING INSTRUCTIONS - WITH TAPE

MOUNTING WALLPLATE WITH TAPE

Caution: It is the installer's responsibility to ensure that installation of this unit complies with all applicable standards, codes, and regulatory requirements. Do not install this dispenser above sources of heat or near sources of ignition/flame.

Mount unit only on dry, clean even wall parts or tiles. Do not install on moving furniture/objects (ie;doors) Do not install where a failure of mounting system, or dripping of product from hands may cause damage to equipment or create a potential safety hazard.

Leave at least 2" of clearance above the wallplate to allow for easy bottle insertion & removal. Dispenser is dishwasher safe, top rack only, max water temp. 140F (60C).

Some tile surfaces have treatments that may inhibit adhesion of tape. Test adhesion against the tile before filling dispenser.

Do not use tape with concrete, brick, or masonry surfaces; surfaces that have a coating/chemical impregnation or porous surfaces.

WALLPLATE MEASUREMENTS

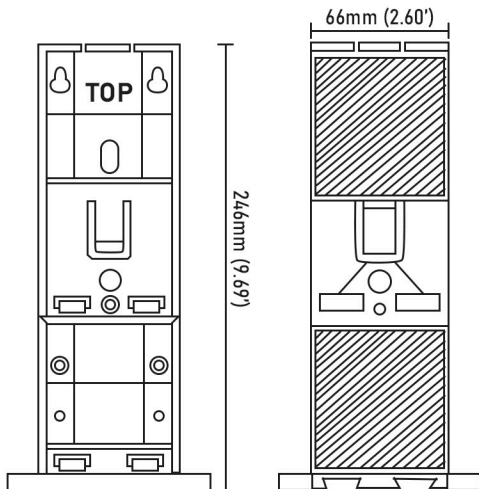

1 Find a flat & smooth surface to place the dispenser. First wipe the surface area with the included alcohol wipe.

Ensure a thorough clean of the surface and let the area dry. **DO NOT** use brick or concrete surfaces.

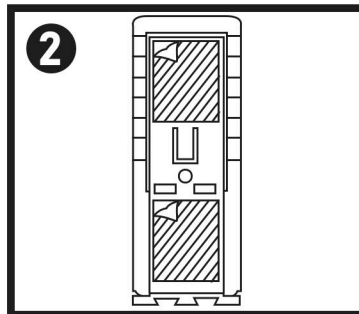

2 Located on the back of the dispenser, are two square adhesive's with thin covers.

Peel back the thin covers to expose adhesive material underneath.

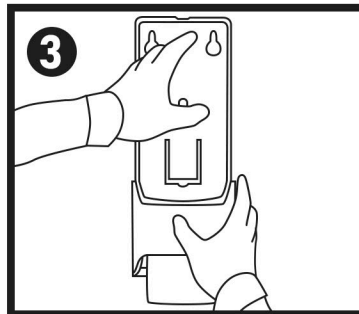

3 Firmly press the dispenser against the flat surface in the same location that was cleaned with the alcohol wipe.

Continue to apply a firm pressure for 10 seconds.

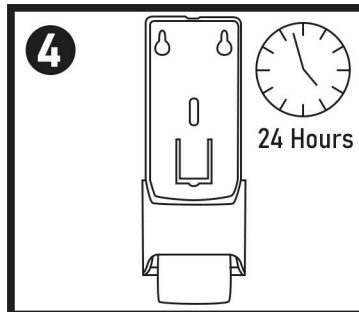

4 **DO NOT** fill the dispenser with cartridges until after 24 hours. This will allow the adhesion to solidify before weight is applied.

DISPENSER MOUNTING INSTRUCTIONS - WITH SCREWS

MOUNTING WALLPLATE WITH SCREWS

Caution: It is the installer's responsibility to ensure that installation of this unit complies with all applicable standards, codes, and regulatory requirements. Do not install this dispenser above sources of heat or near sources of ignition/flame.

Mount unit only on dry, clean even wall parts or tiles. Do not install on moving furniture/objects (ie;doors) Do not install where a failure of mounting system, or dripping of product from hands may cause damage to equipment or create a potential safety hazard.

Leave at least 2" of clearance above the wallplate to allow for easy bottle insertion & removal. Dispenser is dishwasher safe, top rack only, max water temp. 140F (60C).

Wall anchors provided with the dispenser are to be used with masonry surfaces such as brick, tiles, & concrete.

For surfaces other than masonry, the installer must use and select the appropriate fasteners. (i.e; zip plugs, and/or toggle bolts.)

WALLPLATE MEASUREMENTS

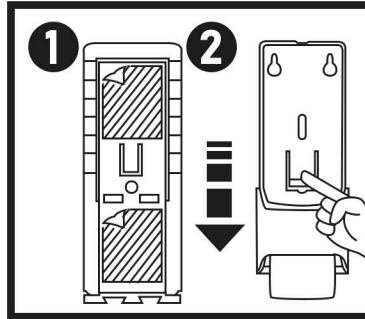
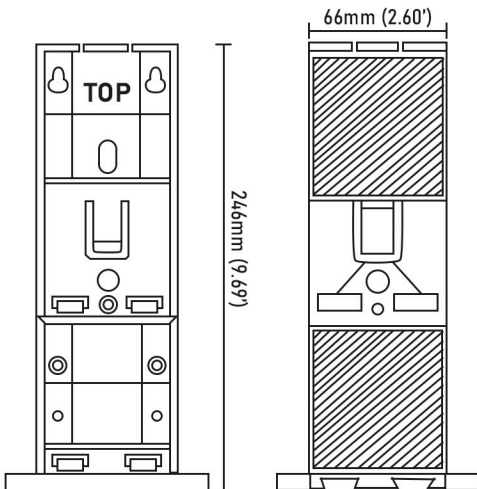

1 Fully peel away the adhesive tap to expose the screw holes used to mount the dispenser.

2 Push the middle plastic tab and pull the back plate down to separate the plate from the dispenser.

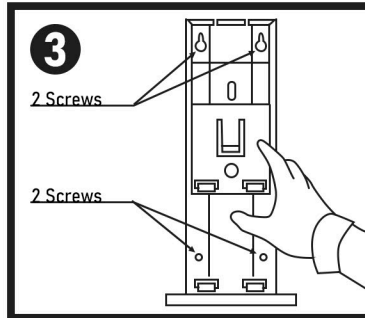

3 Use the separated back plate as a guide for final placement of the screws and dispenser.

The 4 screws provided will go in the marked holes shown in the diagram.

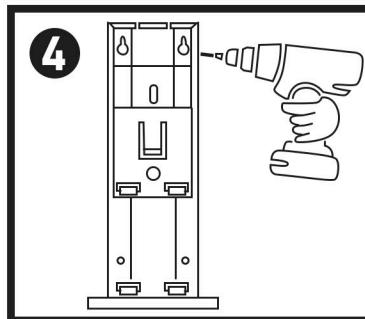

4 Screws provided are meant to be used on drywall, concrete, & brick surfaces.

Use a 3/16" drill bit to mount the back plate to the wall.

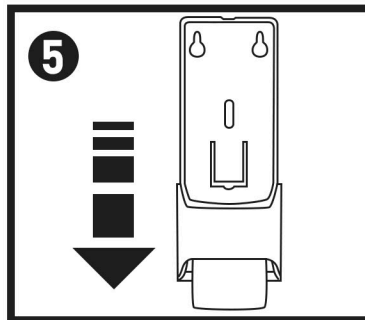

5 With the screws holding the back plate securely against the wall, grab the dispenser and slide it down into position.

The centre clip should click into place.

TECHNICAL DATA SPECIFICATIONS

SETUP + REFILL INSTRUCTIONS

1 Ensure that the dispenser is properly mounted to a flat smooth surface before you place the cartridge into the dispenser.

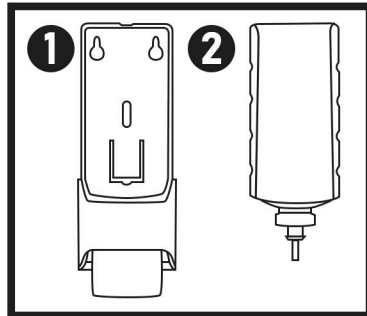

2 Grab a new refill cartridge & prepare to place it into the dispenser with the product label facing from you.

3 With the tip of the cartridge placed above the circle hole of the dispenser base, push cartridge down into the hole until it rests on the base.

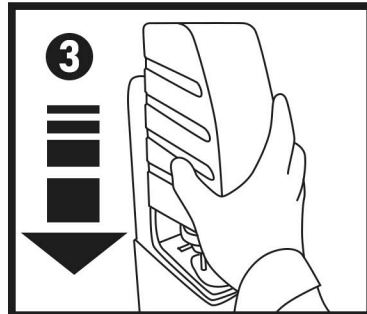

4 Push the cartridge forward toward the dispenser until you feel the cartridge click into place.

The cartridge should now be secure in place and ready to use.

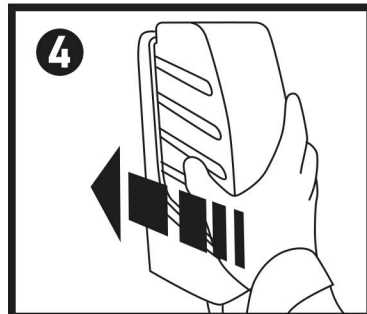

5 To refill the dispenser, simply reverse the steps shown above by pulling the empty cartridge towards you and lifting up the cartridge once it is free from its secure position.

Then place the new cartridge into the dispenser as shown in steps 1-4.

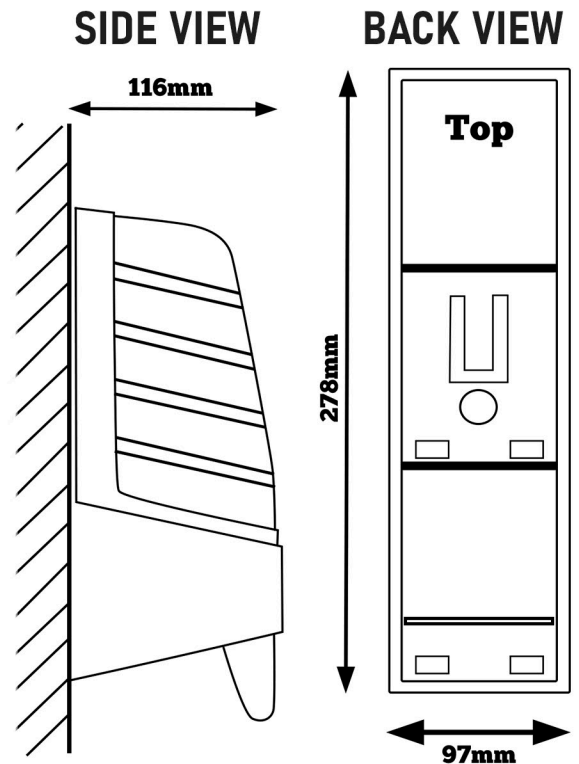
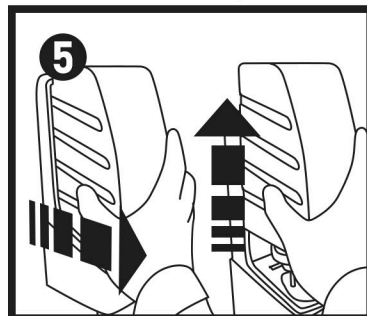

SPECIFICATIONS

Product Code:	10111-NC
Number of Applications:	3,000
Dispensed Formula:	FOAM
Dispenser Capacity:	1,000 (34 o.z)
Features:	Clean-tip Technology

TECHNICAL DATA

Length x Width x Height:	12.25in x 5.50in x 5.25in
Dispenser Weight:	1.00 lbs.
Pieces per Pack:	1 / 6
Pieces per Pallet:	648
Application Type:	MANUAL

Website: www.soapopular.com
E-mail: info@soapopular.com